

# The Study of the Be(p,n) and Be(d,n) Source Reactions

**Thomas N. Massey, Devon K. Jacobs,  
Saleh I. Al-Quraishi, Steven M. Grimes,  
Charles E. Brient**

**Department of Physics and Astronomy, Ohio  
University, Athens, Ohio 45701**

**William B. Howard**

**Department of Physics, Massachusetts Institute  
of Technology, Cambridge, Massachusetts 02139**

**Jacquelyn C. Yanch**

**Department of Nuclear Engineering and  
Whitaker College of Health Sciences and  
Technology, Massachusetts Institute of  
Technology, Cambridge, Massachusetts 02139**

# Application of the Be(p,n) Stopping Target Source Reaction to Medical Physics

Most cancer treatment is based on gamma rays which have a low Linear Energy Transfer(LET). Neutrons produce higher LET through the (n,p) and (n, $\alpha$ ) reactions. The high LET radiation is more damaging to the tumor compared to the surrounding healthy tissue than low LET radiation. The high LET radiation is also more localized to the tumor area.

## **Boron Neutron Capture Therapy**

Some isotopes, such as  $^{10}\text{B}$ , have a positive Q-value and a large low energy cross section for (n, $\alpha$ ). A low energy neutron of 0.1 MeV can produce a  $\sim 2.5$  MeV alpha particle. These low energy neutrons produce little damage to normal tissue. If the boron can be introduced into the tumor selectively the dose is highly concentrated.

The Be(p,n) reaction is currently being used as a source of the low energy neutrons needed by Boron Neutron Capture Therapy.

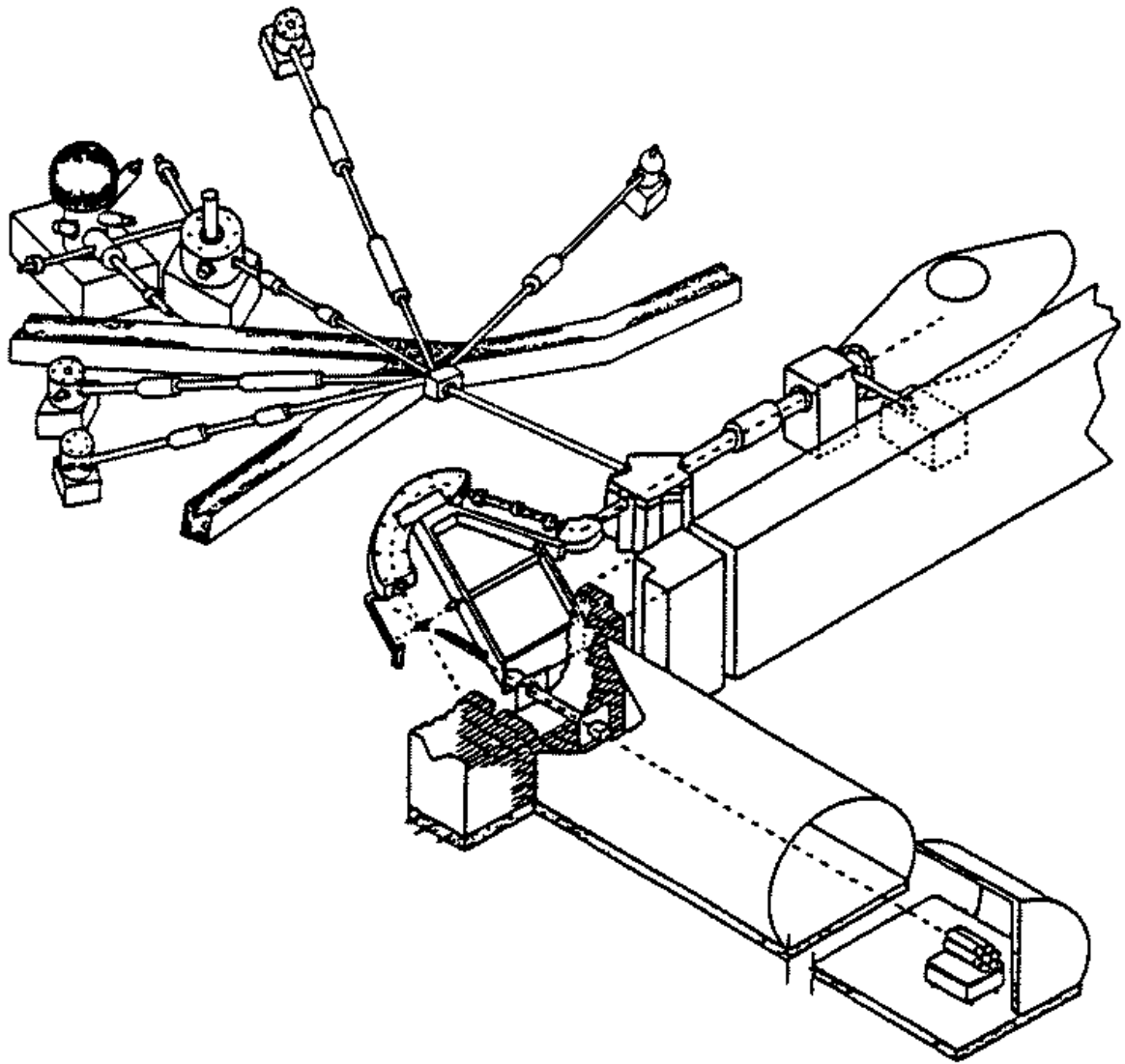

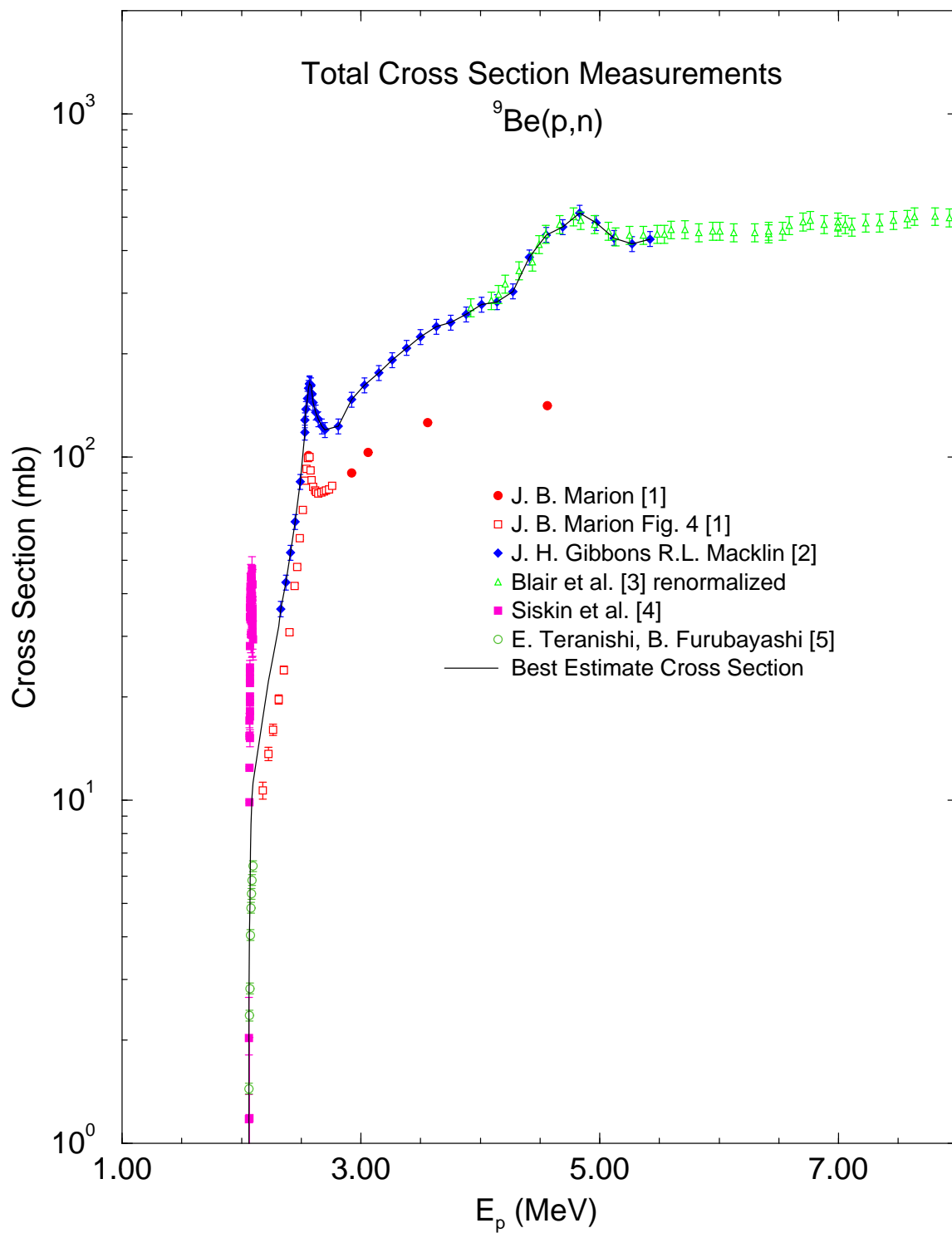

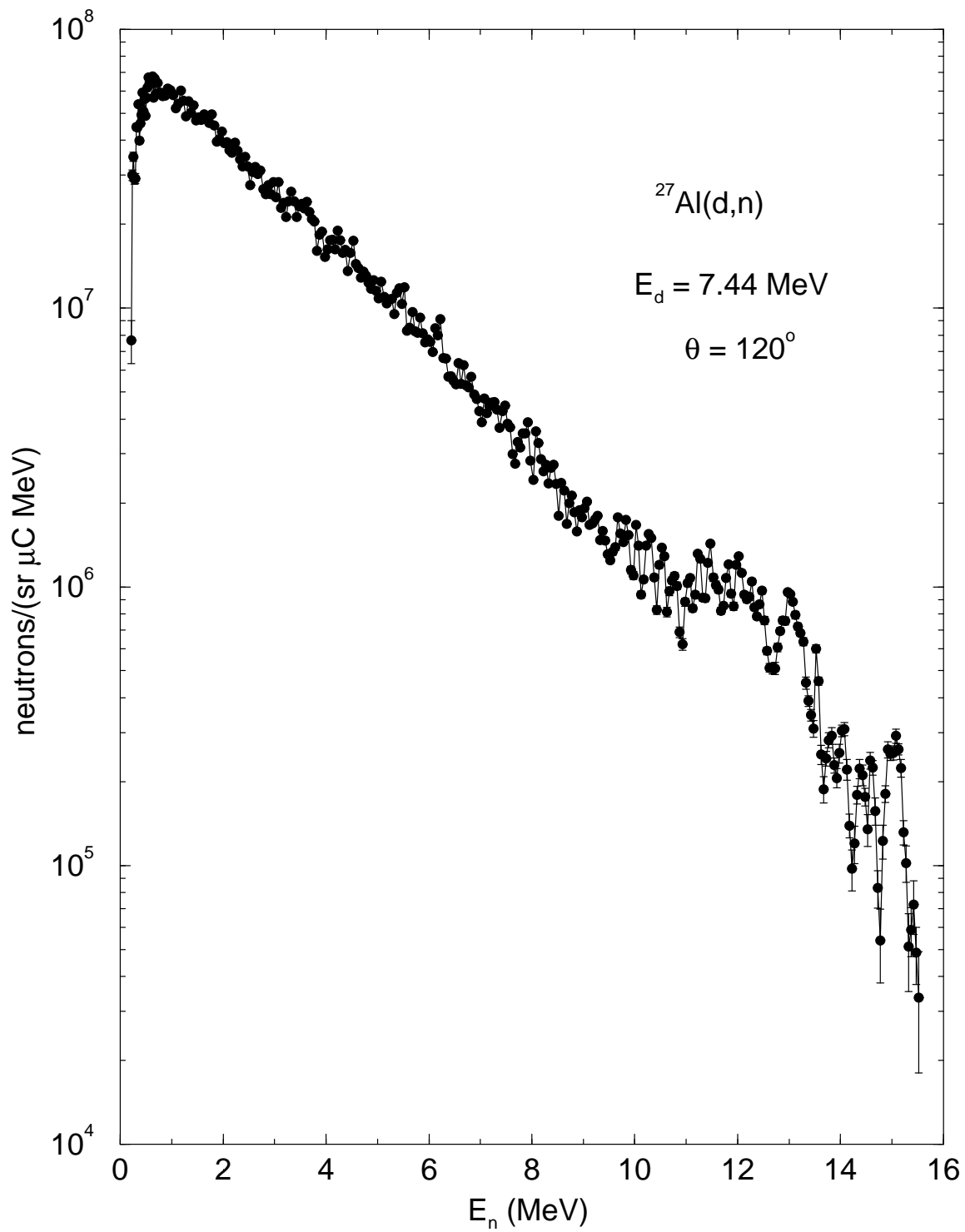

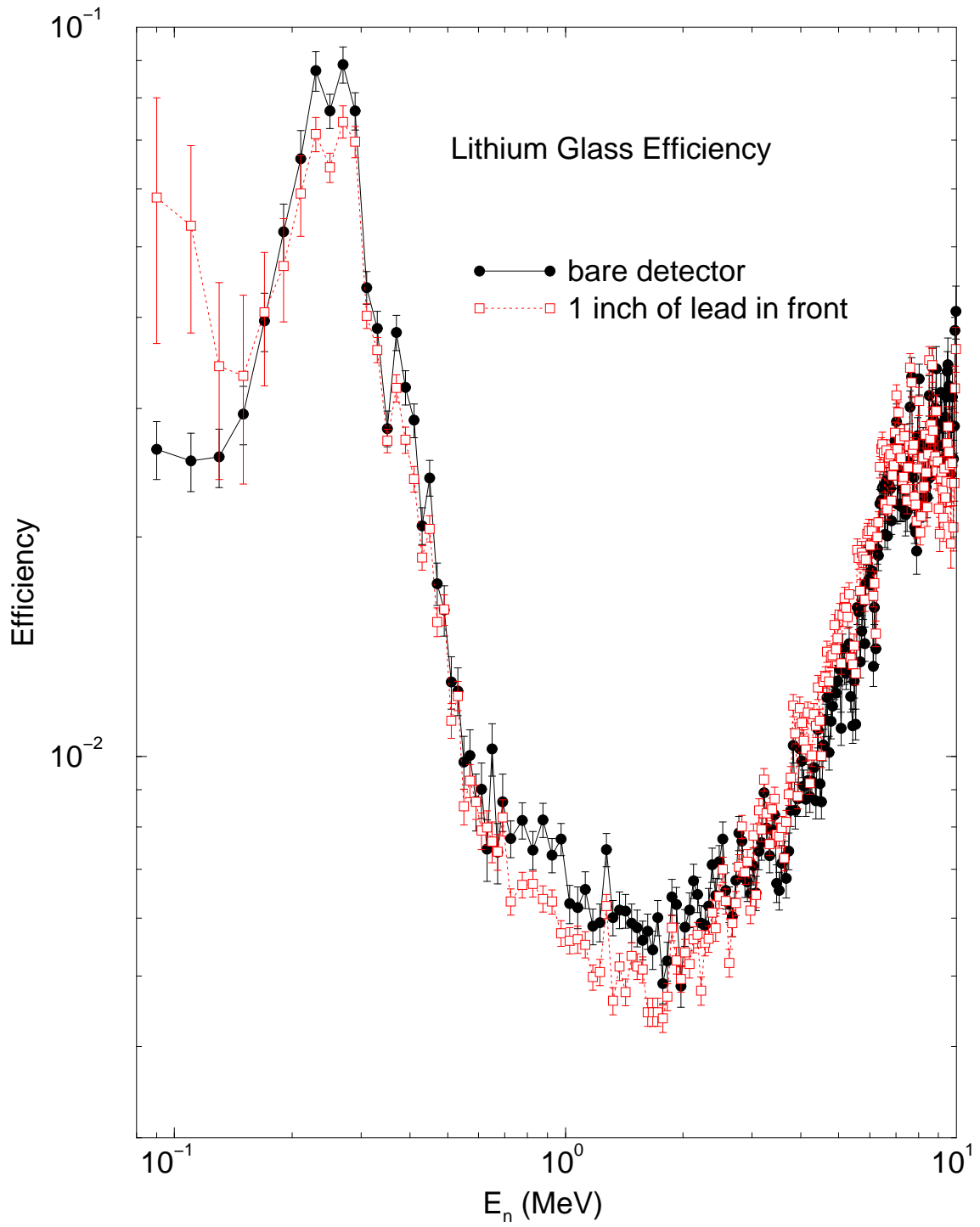

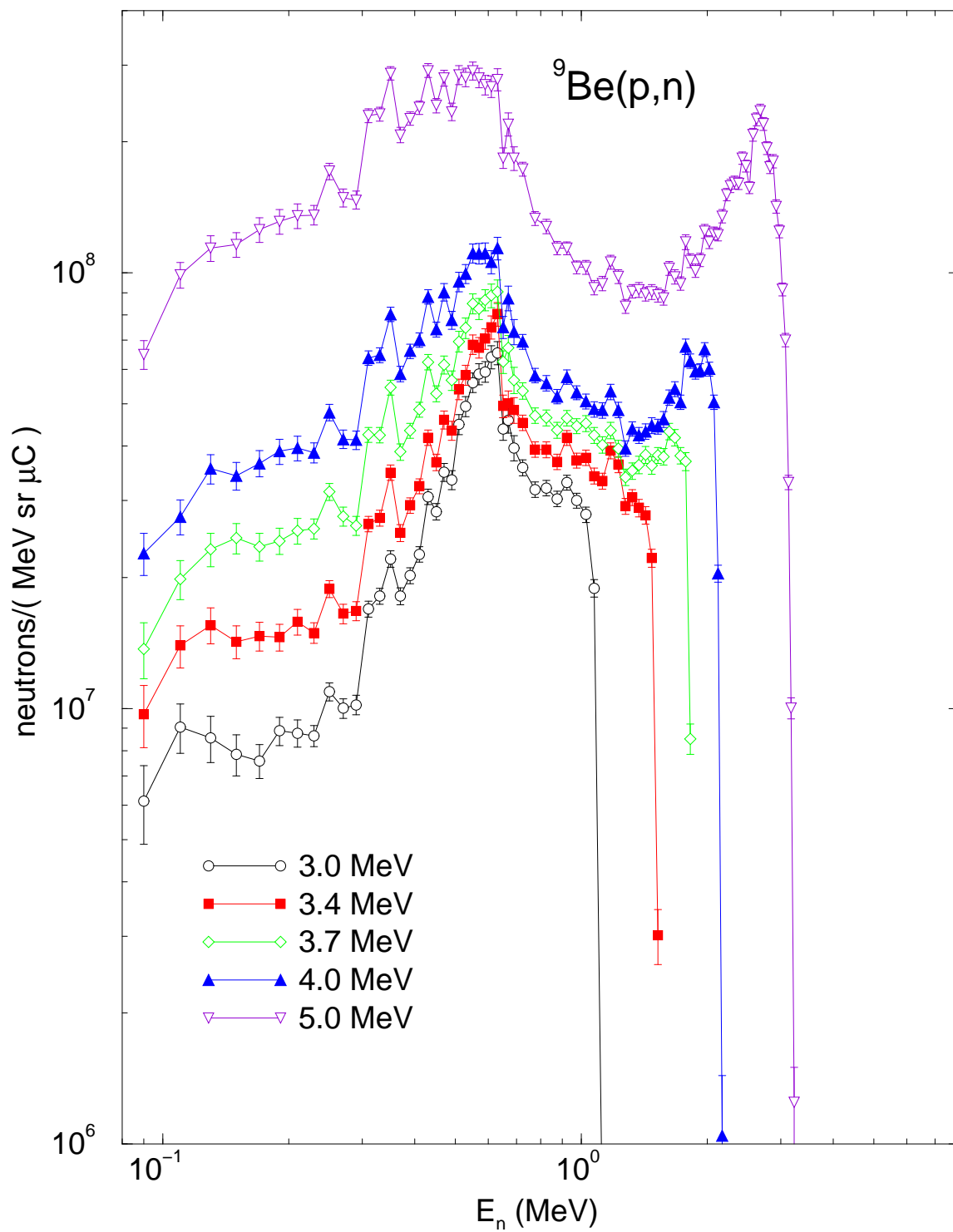

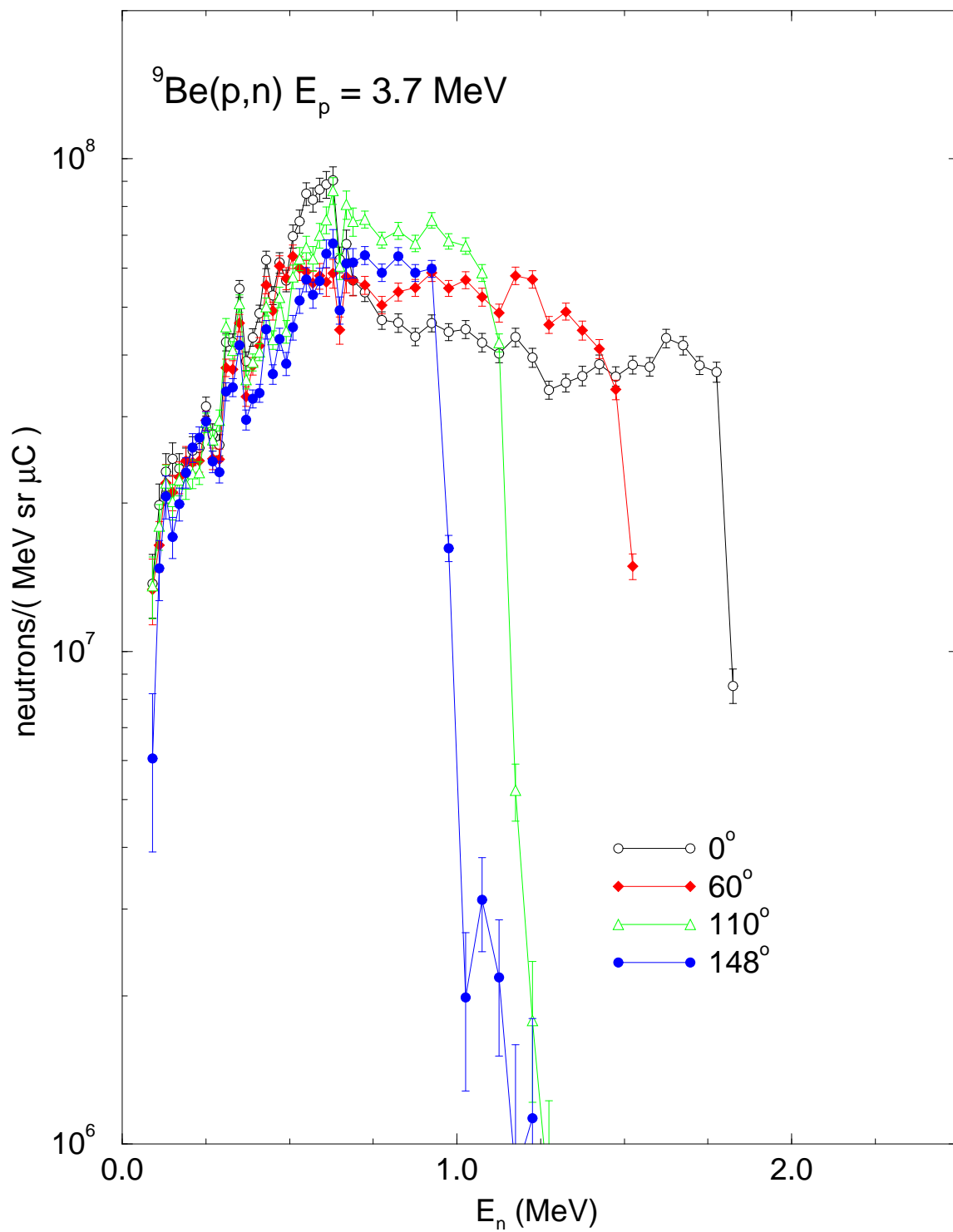



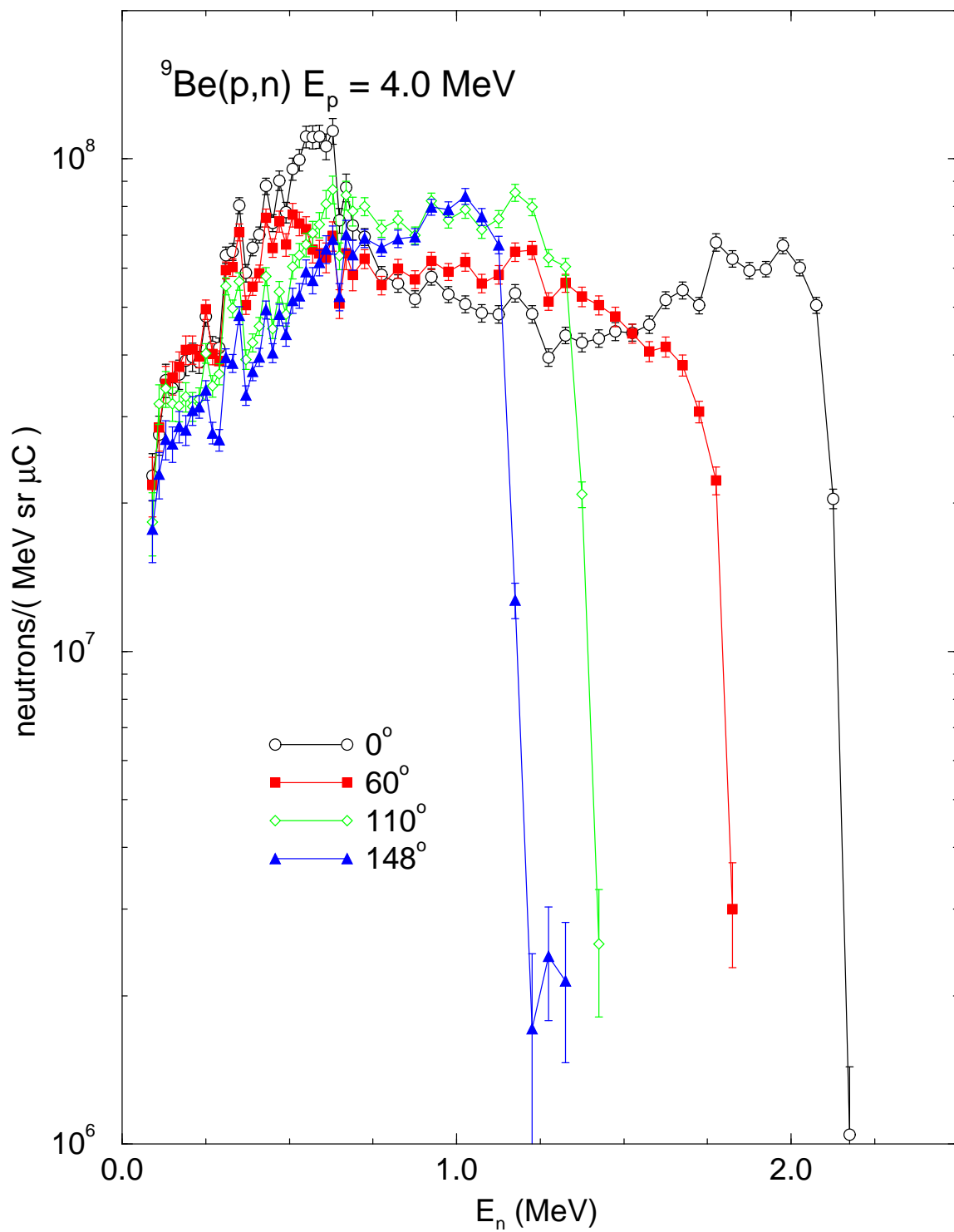

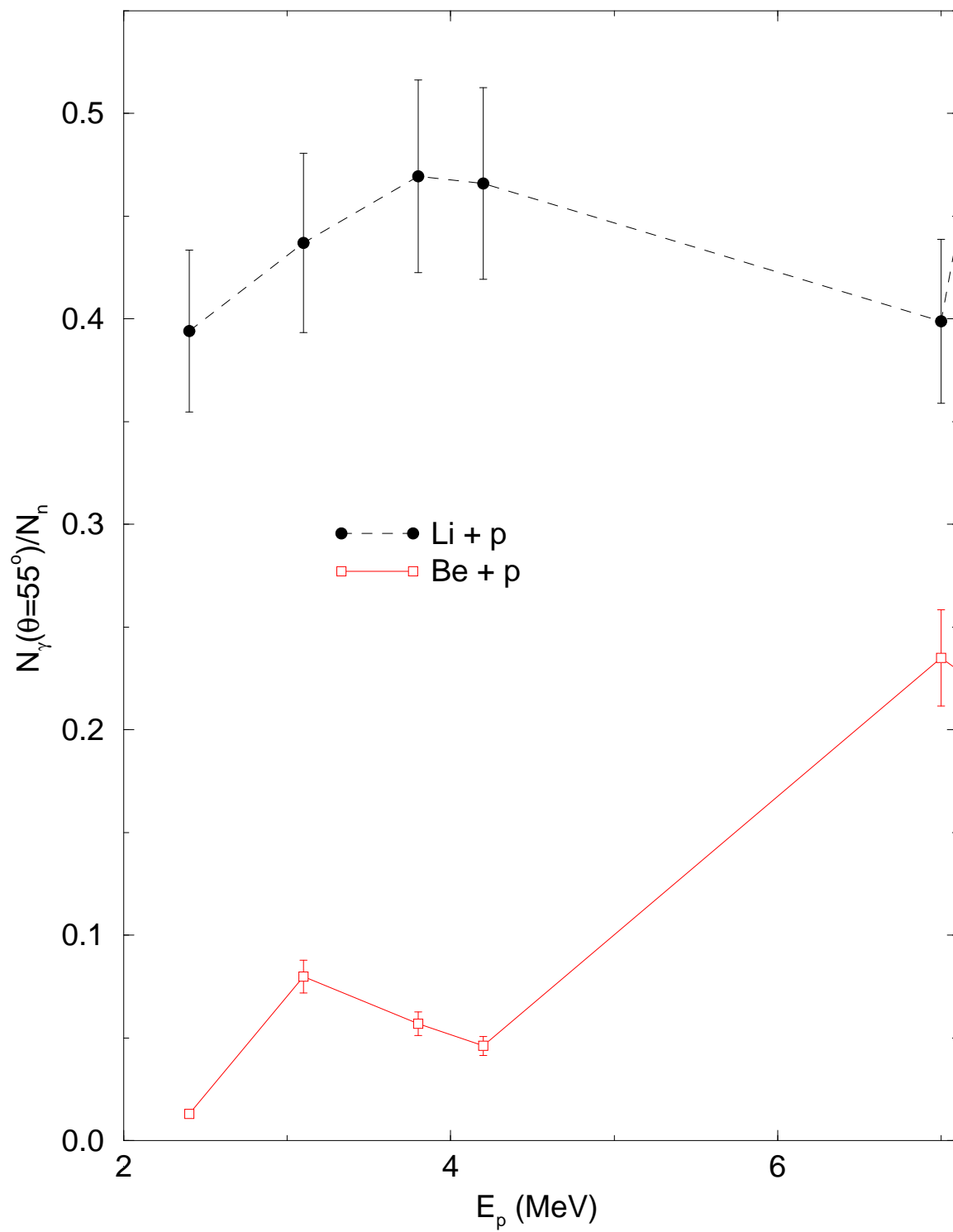

# Measurements of Be(p,n)Source Reaction

- Excitation function measurements from 3.0 to 5.0 MeV.
- Angular distributions at 3.8 and 4.0 MeV.
- Determined total neutron cross section at 3.8 and 4.0 MeV.
- Verified previous total neutron cross section measurements.
- Calculated the number of gammas to neutron based upon both previous and current results.

# Motivation for Measurement of $\text{Be}(d,n)$ Source Reaction

- Neutron Radiography application needed improved neutron energy spectra and angular distributions.
- This reaction is currently used for the integral testing of nuclear data.
- Only zero degrees and a few angular distributions measured previously.

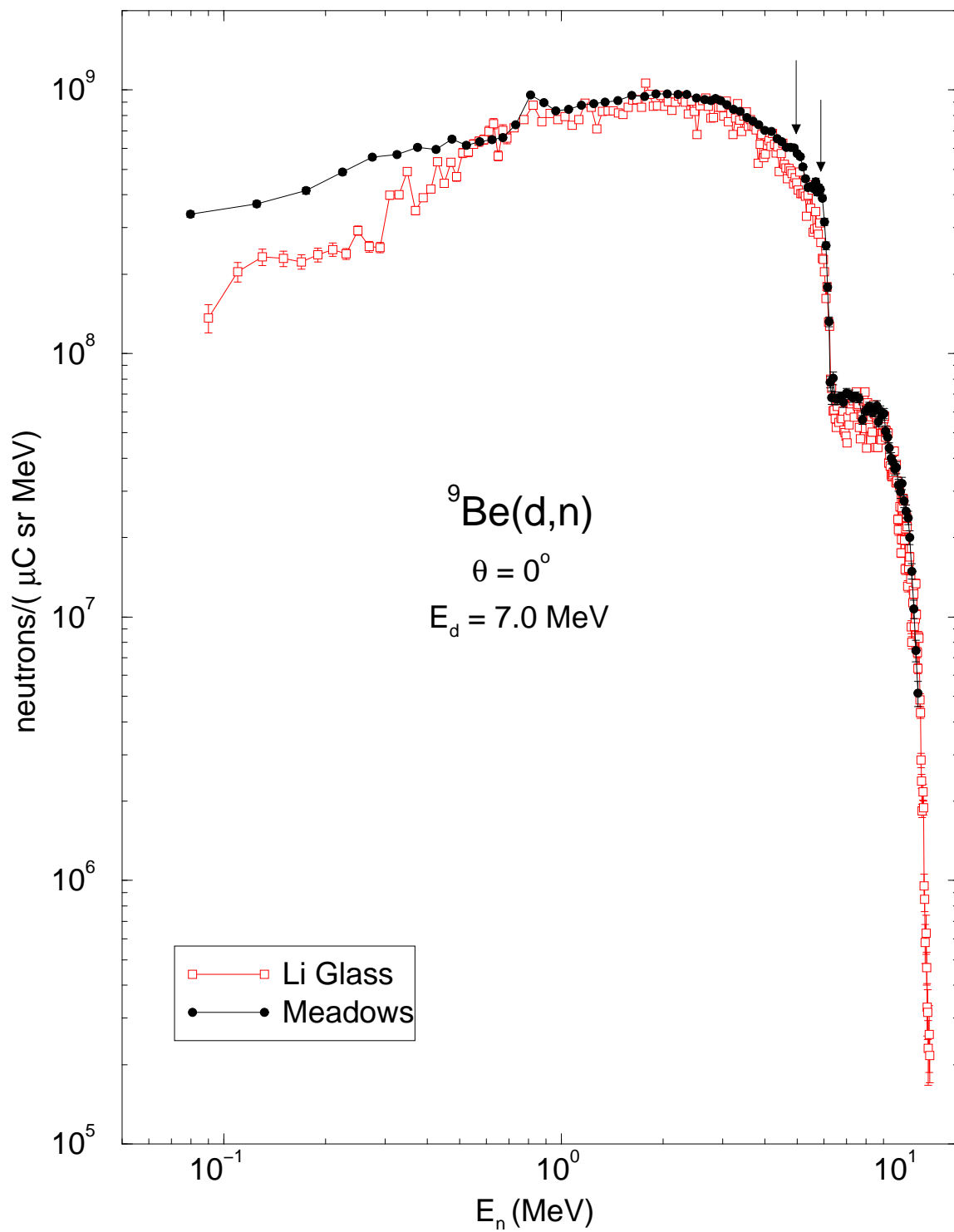

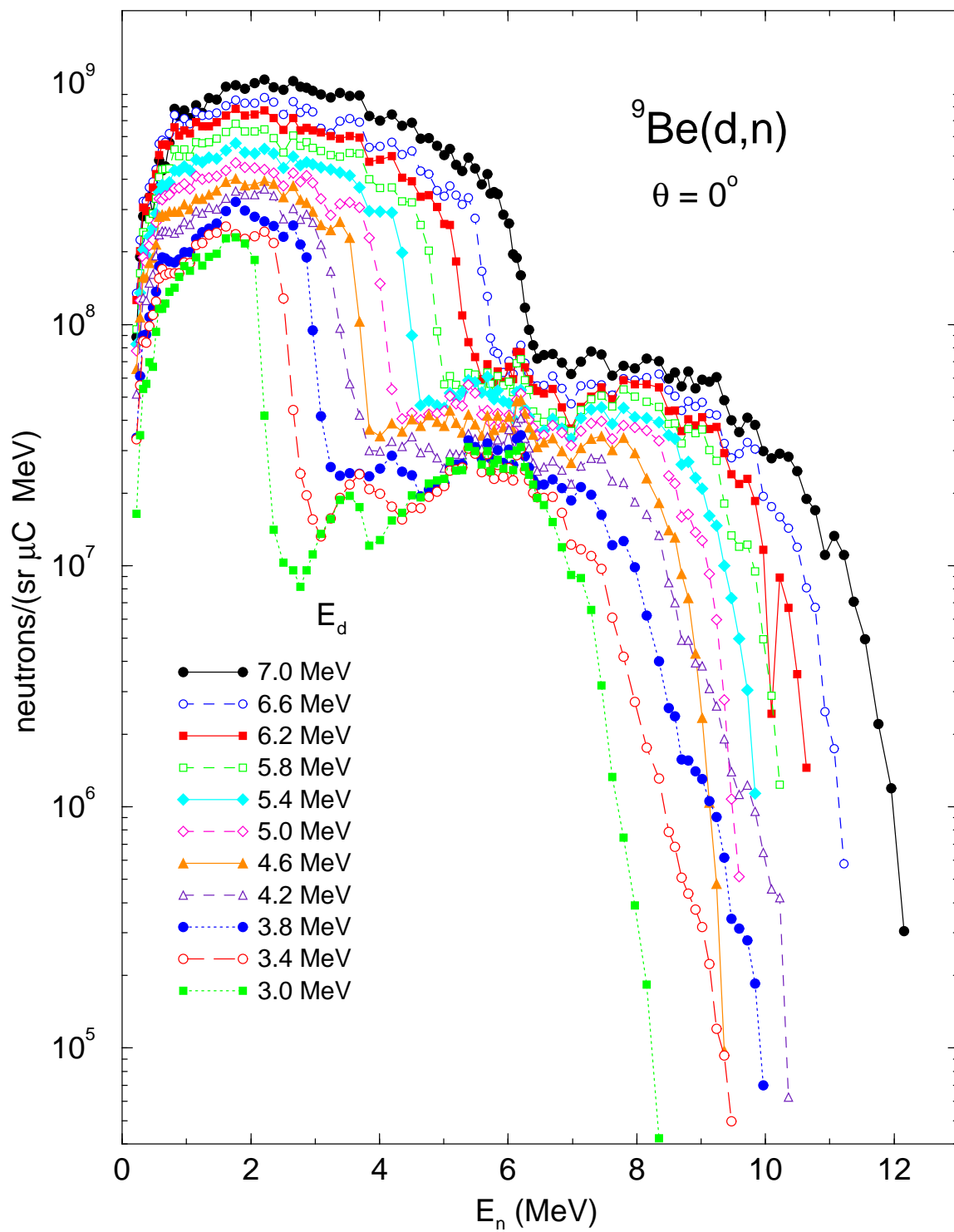

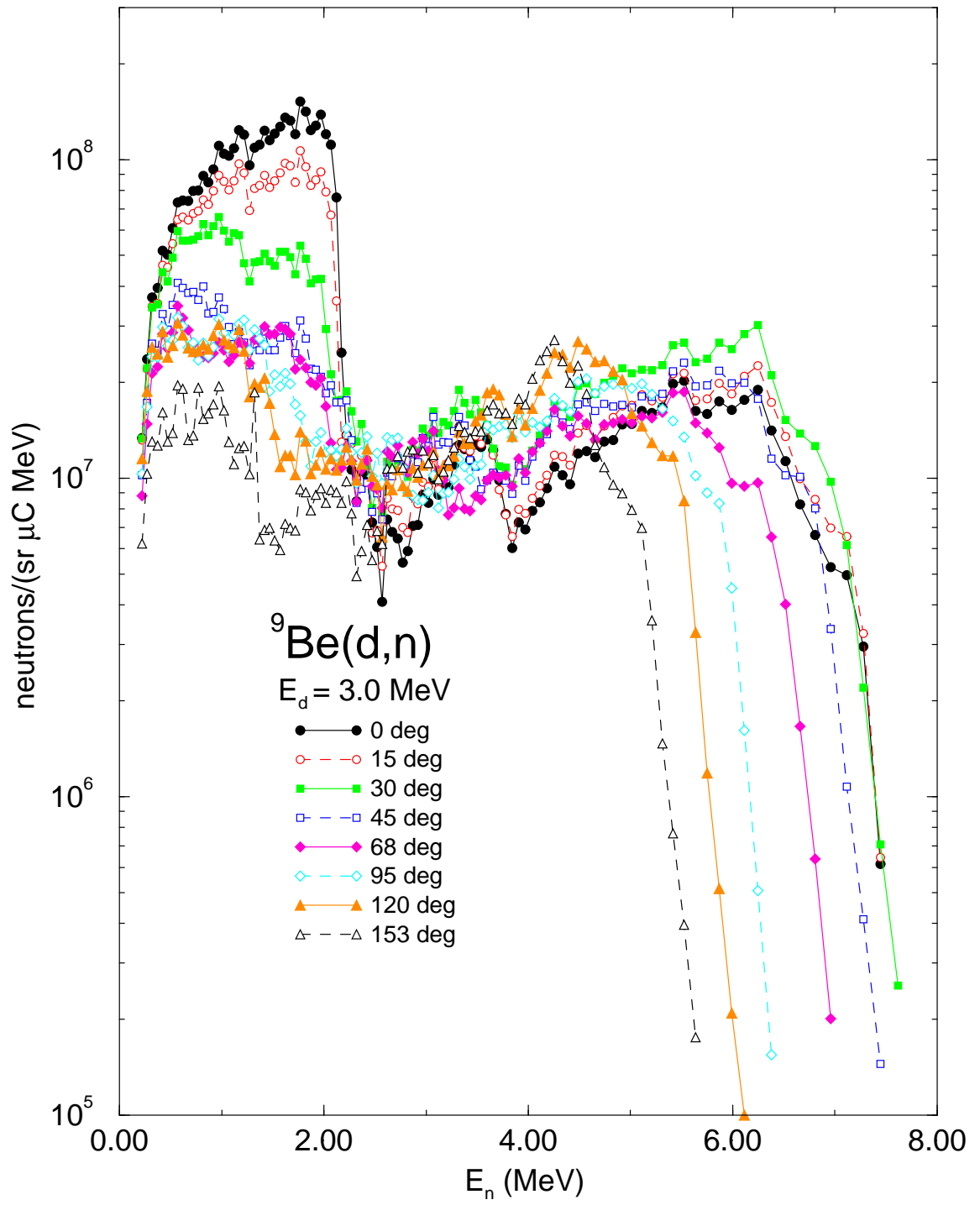

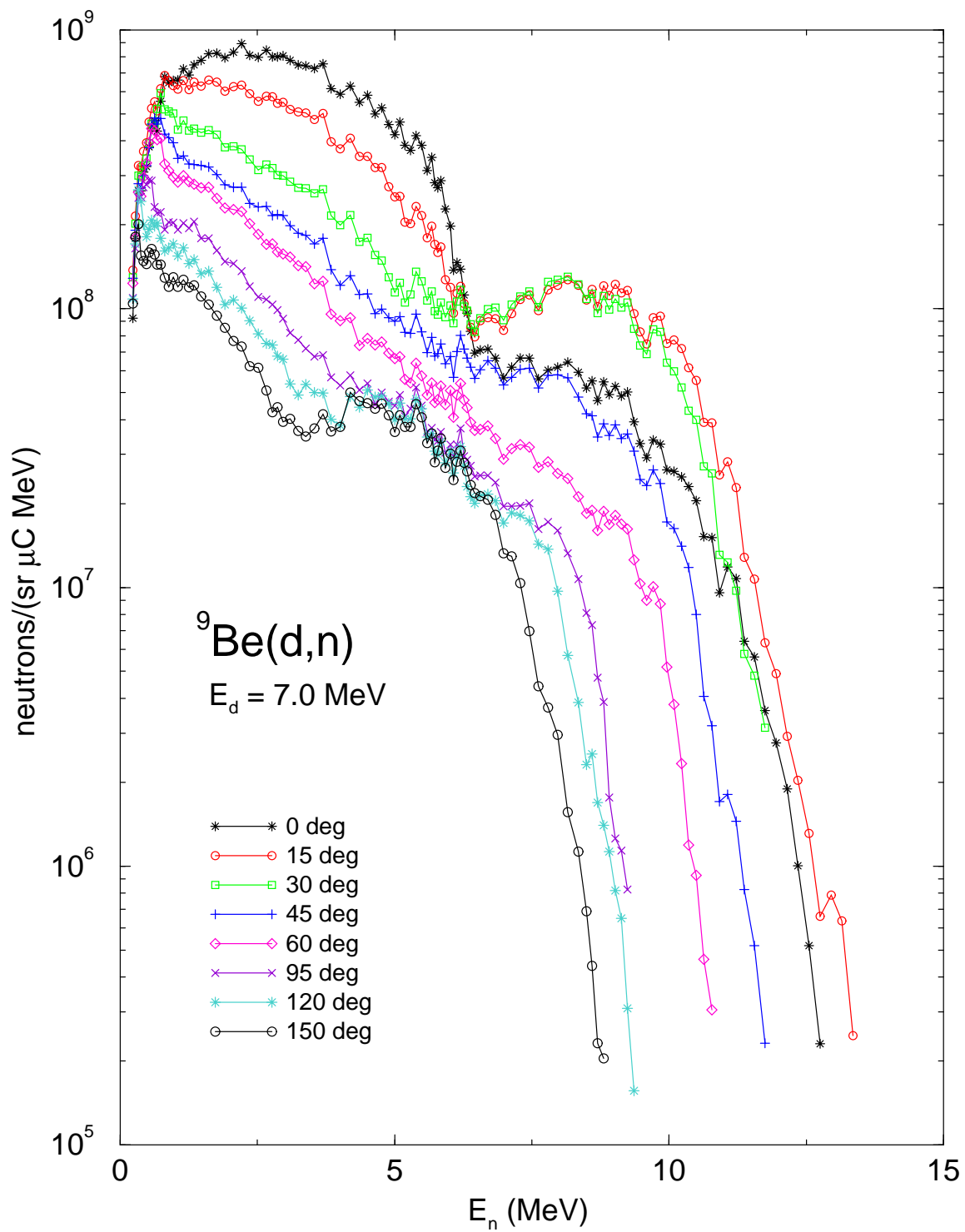



# Results of Measurement of Be(d,n) Thick Target Source Reaction

- Neutron Energy Spectra Angular distributions at 3.0 and 7.0 MeV
- Excitation function of the Neutron Energy Spectra from 3.0 and 7.0 MeV
- Comparison with results from Meadows show a difference in the results at low energies and two peaks in the neutron energy spectra which are likely to associated with implanted deuterons via the d(d,n) reaction.